

LC-360

GENERAL

The LC-360 is an innovative 360° ceiling mount indoor motion SenSwitch™ designed for automatic lighting control and energy management of industrial, commercial and residential applications. Lights will be switched on automatically when LC-360 detects the human body motion. Light will be switched off automatically if no motion is further detected before the delay time expire.

INSTALLATION

Caution: Some local building codes may require installation by a qualified electrician. Consult an electrician about safety rule and correct wiring.

Switch off the power to the lighting circuit before wiring.

- Loosen the cover locking screw, remove the cover from main unit. Releases two fixing screws on the main unit to disassemble the mounting plate.
- Fix the mounting plate at the location where the optimum coverage can be obtained.

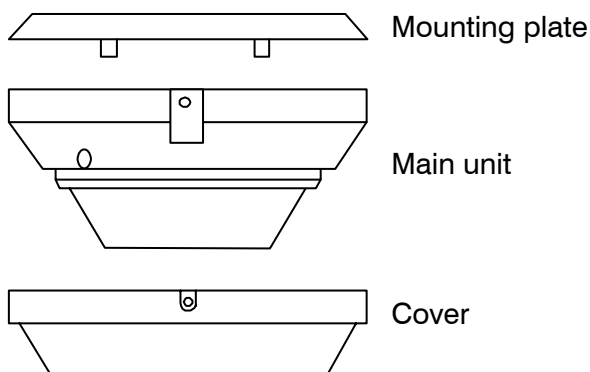

- Connect the wires according to the diagram of the desired control mode. Replace the main unit, then test can be conducted.

L : Live of AC mains

N : Neutral of AC mains

⊗: Switched live of light

Warning !!!

Reverse connection of "live" and "neutral" wires may cause malfunction or permanent damage to the unit. Identify the feature of before wiring.

Installation Instructions

CONNECTION DIAGRAM

A: Automatic mode

The following connections provide automatic control of the light by detecting the motion.

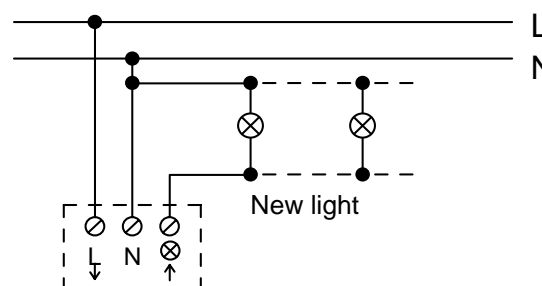
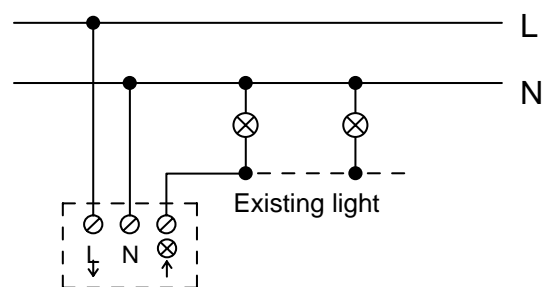

B: Automatic mode with manual override on

An additional manual switch in parallel with the LC-360 will provide automatic control of the light when the switch is off. The light will be constantly on, if the switch is on, disregard any motion or light level.

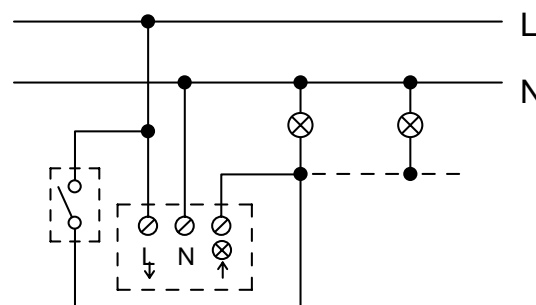

Apply the main power, light will remain on about 30 seconds for sensor to warm up. Walk in the detection range at normal speed, light will be switched on automatically when motion is detected.

DETECTION RANGE

Detection range of LC-360 varies by its mounting height. Following formula gives the maximum range at different ceiling heights.

Maximum Detection Range at 25°C

Mounting m Height (ft)	2.4 (8)	2.7 (9)	3.0 (10)	3.6 (12)
Detection m Range (ft)	5 x 5 (16 x 16)	6 x 6 (20 x 20)	8 x 8 (26 x 26)	12 x 12 (40 x 40)

Side View

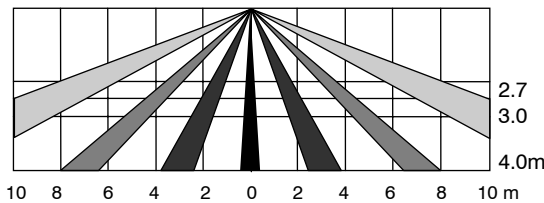

Top View

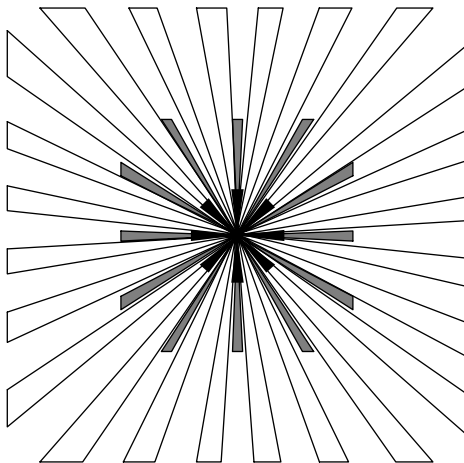

TIME & LUX CONTROL

A: TIME

TIME control determines the light-on delay time after the last motion is detected. Different delay time can be set by placing the jumper head at different pin.

A*	B	C	D	E	F	O
5s	30s	1'	3'	5'	10'	20'

A*: Factory set TIME control

O :Jumper head removed

B: LUX

LUX control determines the operation of LC-360 by sensing the ambient light level. Different light level can be set by placing the jumper head at different pin.

N	M	D*
Night (3 ~ 5 lux)	Dusk (5 ~ 15 lux)	Day (24 hours)

D*: Factory set LUX control

SPECIFICATIONS

Detection method.....Passive Infrared (PIR)

Operating voltage110/230 VAC, 50/60 Hz

Max. load10A @ 250 VAC Resistive

Mounting height..... 2.4 - 3.6 m (8 - 12 ft)

Op. Temperature.....-20° - + 50°C (-4° - + 122°F)

Dimensions 100 x 100 x 46 mm

WARRANTY

Thank you for purchasing IR-TEC product. The LC-360 Motion SenSwitch has a 12-month warranty from date of purchase provided the unit is installed by an electrician according to the instruction and local wiring regulation. Any malfunction caused by defects in material or workmanship will be corrected at no charge. In the event of a warranty claim, the unit must be returned to the point of purchase or IR-TEC distributor at your expense. Warranty is void on any unit which has been tampered with, damaged by accident, improper operation or incorrect installation.

Taiwan patent No. 96267

Taiwan patent No. 40265

U.K Patent pending

Manufactured by:

IR-TEC INTERNATIONAL LTD.

Taipei, Taiwan

